

## CAV-2 Module **Blister Taping Module**

Taping module for the automatic sealing of electric or mechanic components into a blister tape. The components are inserted by a component handling system into the blister tape. At the sealing station the blister tapes are sealed and afterwards reeled-up by a motor driven reeling-up station. The change of the blister tape reels and the sealing tape is done manually.



**Picture 1:** CAV-2 Module taping direction right to left

We are specialized in

Radial Taping

Blister Taping

Fuse Assembly

Test & Sorting

[www.mbl-machines.com](http://www.mbl-machines.com)

# MBL

GmbH & Co. KG

# CAV-2 Module

## **Blister Taping Module**

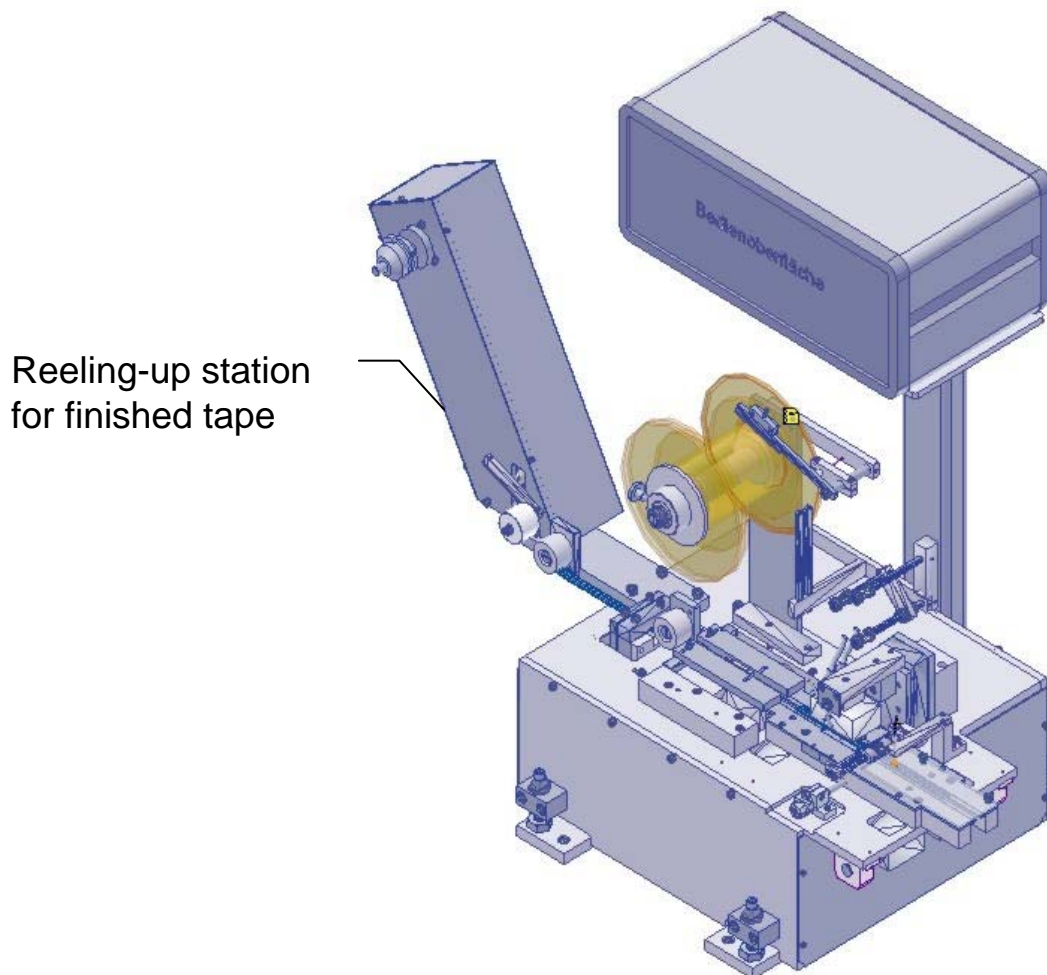

**Picture 2:** CAV-2 Module taping direction right to left

# MBL

## GmbH & Co. KG

mailto: [info@mbi-machines.com](mailto:info@mbi-machines.com)  
Web: [www.mbl-machines.com](http://www.mbl-machines.com)

Von-Miller-Str. 1 D- 93092 Barbing–Unterheising Tel.:+49 (0) 9401 9205 0 Fax +49 (0) 9401 9205 90

# CAV-2 Module

## **Blister Taping Module**

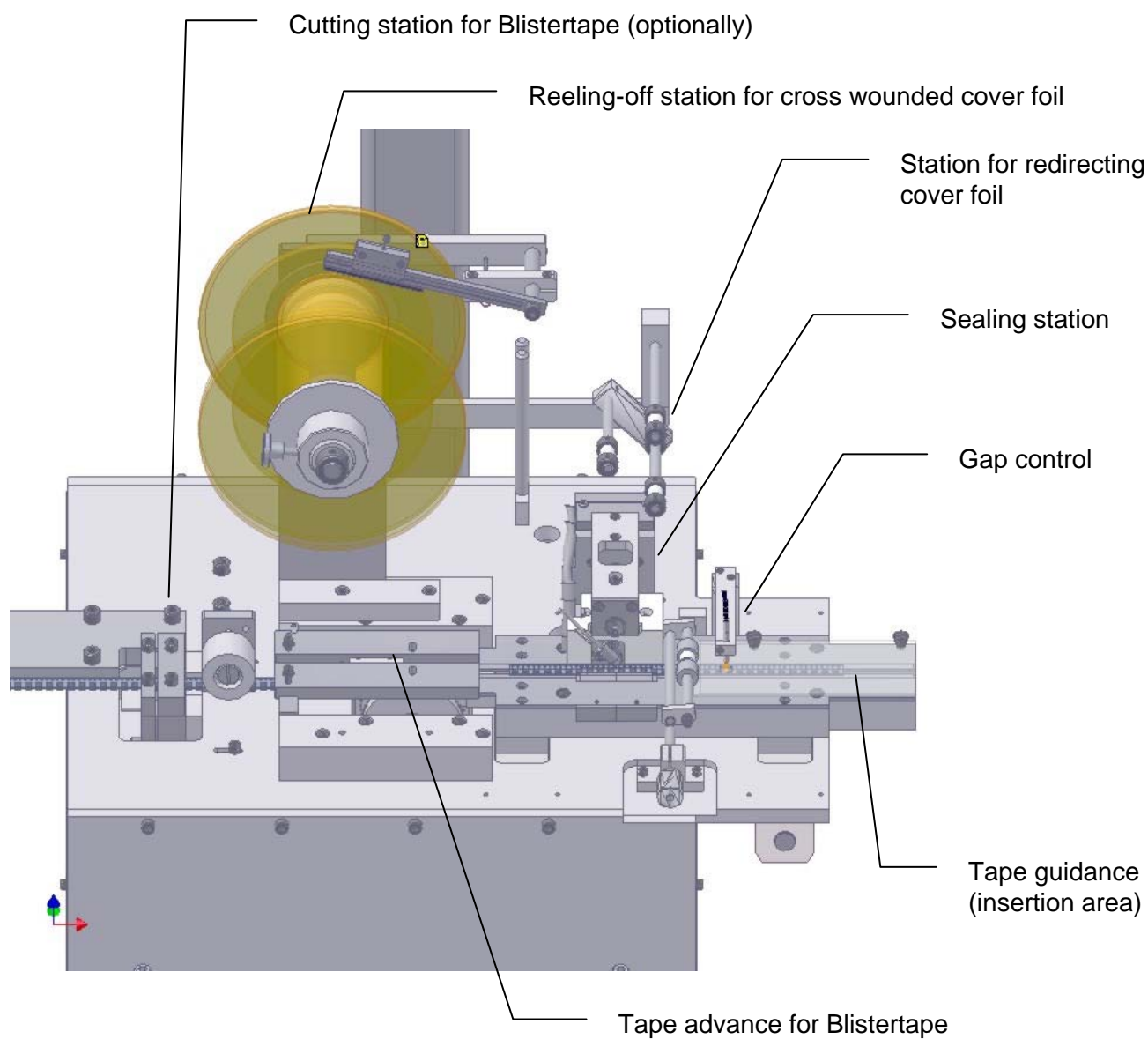

**Picture 3:** Detail sealing area

# **MBL**

## **GmbH & Co. KG**

mailto: [info@mbi-machines.com](mailto:info@mbi-machines.com)  
Web: [www.mbi-machines.com](http://www.mbi-machines.com)

Von-Miller-Str. 1 D- 93092 Barbing–Unterheising Tel.:+49 (0) 9401 9205 0 Fax +49 (0) 9401 9205 90

# CAV-2 Module

## **Blister Taping Module**

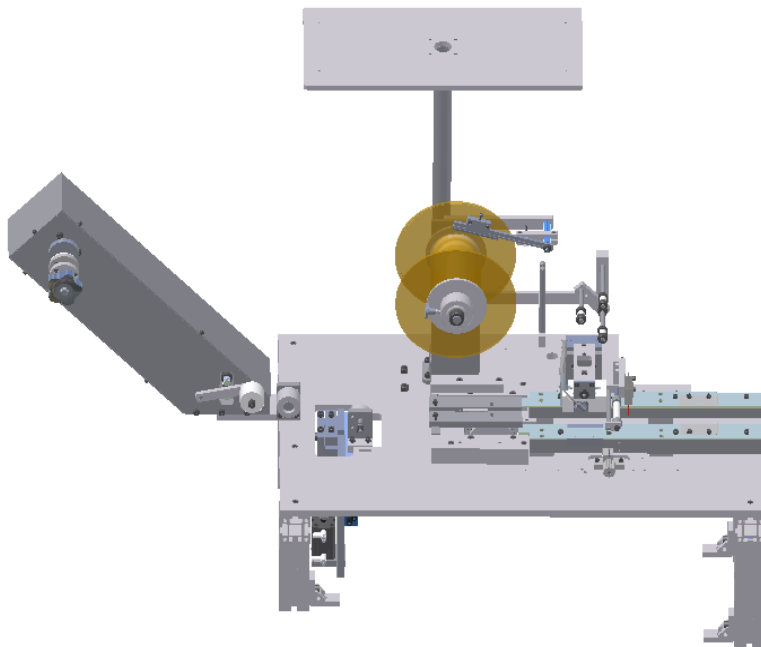

CAV-2#03

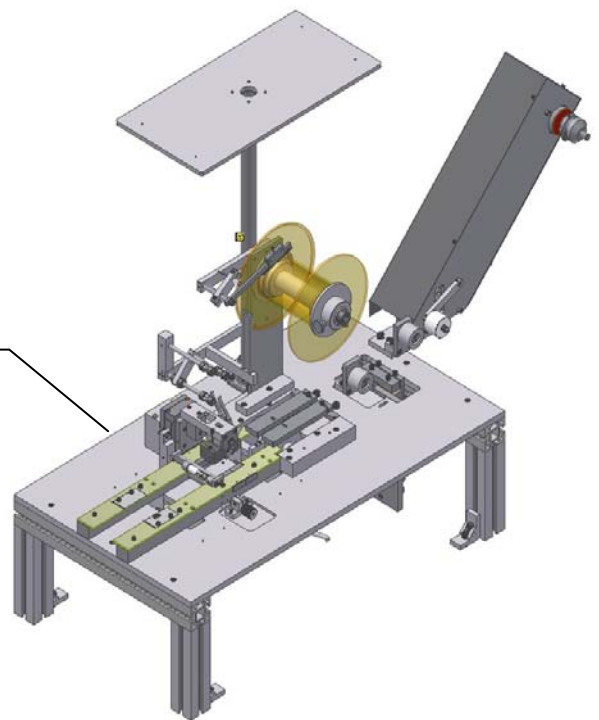

**Picture 5:** Another variant of a taping module

# MBL

## GmbH & Co. KG

mailto: [info@mbl-machines.com](mailto:info@mbl-machines.com)  
Web: [www.mbl-machines.com](http://www.mbl-machines.com)

Von-Miller-Str. 1 D- 93092 Barbing–Unterheising Tel.:+49 (0) 9401 9205 0 Fax +49 (0) 9401 9205 90

# CAV-2 Module

## **Blister Taping Module**

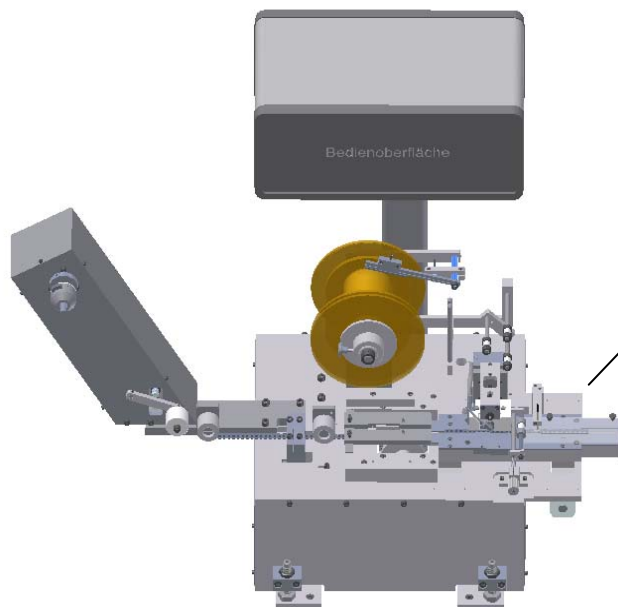

**CAV-2#01**

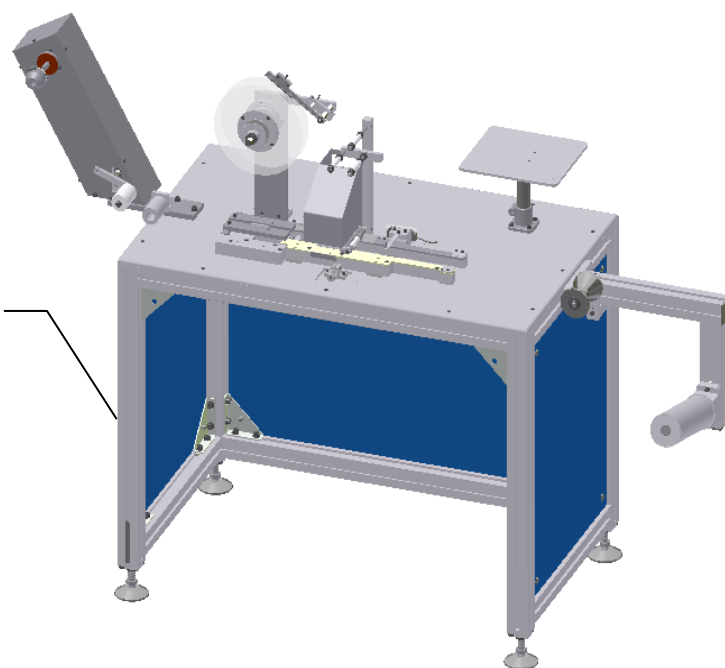

**CAV-2#04**

Manual Blister Taping Machine,  
insertion manually with the option to  
extend to a Semi-Automatic Machine

# MBL

GmbH & Co. KG

mailto: [info@mbl-machines.com](mailto:info@mbl-machines.com)  
Web: [www.mbl-machines.com](http://www.mbl-machines.com)

Von-Miller-Str. 1 D- 93092 Barbing–Unterheising Tel.:+49 (0) 9401 9205 0 Fax +49 (0) 9401 9205 90